

SECTION B-B
SCALE 1 : 48

Corrosion allowance is removed from all pressure components

Materials		Shell Thickness	
Description	Mat. Spec.	Uncorroded	Corroded
Shell	SA-299 Grade A	1.37	1.34
Column Stub	SA-516 70	1.42	1.39
Column Below Stub	A252-2	1.46	1.43
Column Bracing Members	G40.21-350W	1.48	1.45
Column Base Plate	G40.21-300W	1.48	1.45

UNLESS OTHERWISE SPECIFIED
DIMENSIONS ARE IN INCHES
TOLERANCES UNLESS SHOWN BELOW
FINISH: AS MANUFACTURED
SURFACE ROUGHNESS: 32 Ra

REV	DESCRIPTION	DATE	APVD
REVISIONS			
Pressure Vessel Engineering 12800 S. 26th St., Suite 100, Overland Park, KS 66210 Tel: 913.241.1100 Fax: 913.241.1101 www.pveeng.com			
PROPRIETARY NO PART OF THIS DOCUMENT MAY BE REPRODUCED, STORED IN A RETRIEVAL SYSTEM, OR TRANSMITTED IN ANY FORM WITHOUT THE WRITTEN PERMISSION OF Pressure Vessel Engineering		FILE Sphere FEA Drawing Default	
CUSTOMER Pressure Vessel Engineering		PROJECT PVE-4225	
DESIGNED BY BTV		DATE 7/28/10	
CHECKED BY BTV		DATE 7/28/10	
APPROVED [Signature]		SCALE 1:128	
MATERIAL [Symbol]		HEIGHT lbs	
FINISH [Symbol]		REVISION D PVEdwg-4225-0-0	
SCALE 1:128		SHEET 1 OF 3	

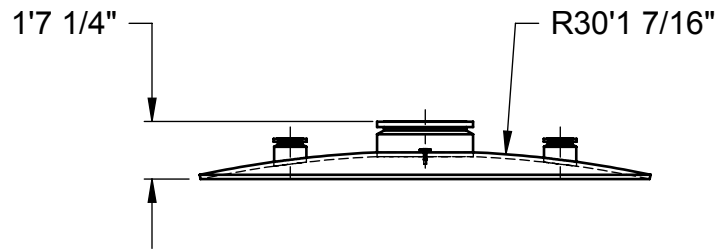
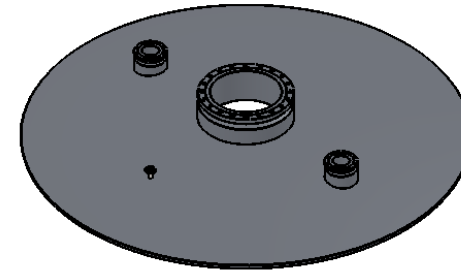
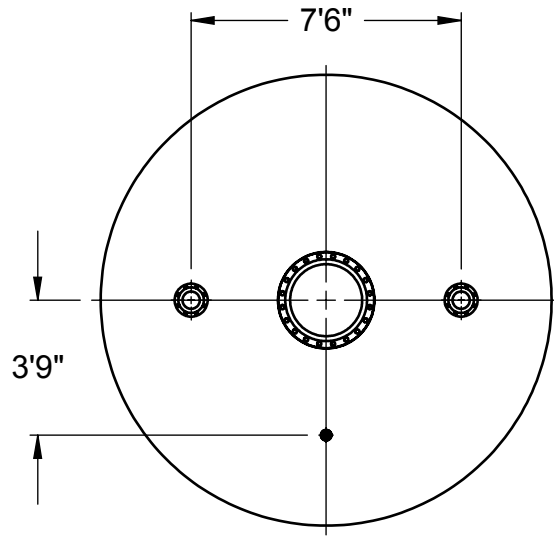

PROPRIETARY AND CONFIDENTIAL
 THE INFORMATION CONTAINED IN THIS DRAWING IS THE SOLE PROPERTY OF <INSERT COMPANY NAME HERE>. ANY REPRODUCTION IN PART OR AS A WHOLE WITHOUT THE WRITTEN PERMISSION OF <INSERT COMPANY NAME HERE> IS PROHIBITED.

		UNLESS OTHERWISE SPECIFIED:	NAME	DATE	TITLE: TOP ASSEMBLY		
		DIMENSIONS ARE IN INCHES TOLERANCES: FRACTIONAL ± ANGULAR: MACH ± BEND ± TWO PLACE DECIMAL ± THREE PLACE DECIMAL ±	DRAWN				SIZE
		INTERPRET GEOMETRIC TOLERANCING PER:	CHECKED		A	PVEdwg-4225-0-0	-
		MATERIAL	ENG APPR.				
		FINISH	MFG APPR.		SCALE: 1:64	WEIGHT:	SHEET 2 OF 3
NEXT ASSY	USED ON		Q.A.				
APPLICATION		DO NOT SCALE DRAWING	COMMENTS:				

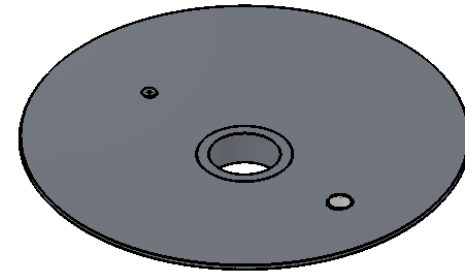
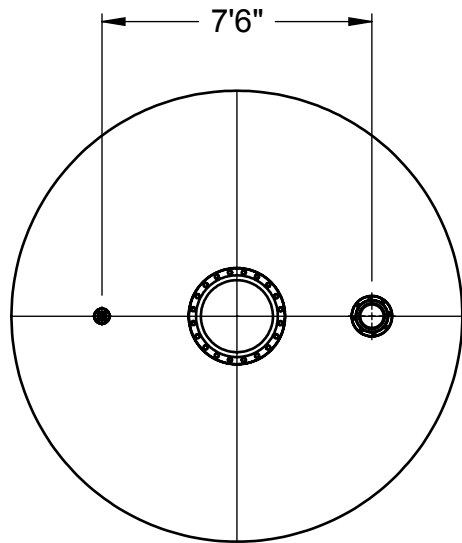
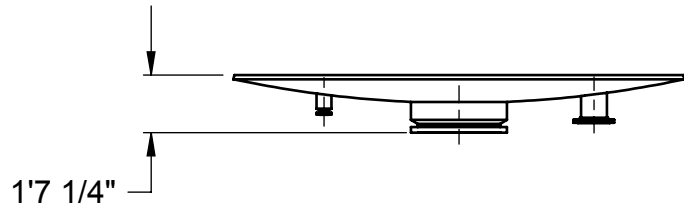

PROPRIETARY AND CONFIDENTIAL
 THE INFORMATION CONTAINED IN THIS DRAWING IS THE SOLE PROPERTY OF <INSERT COMPANY NAME HERE>. ANY REPRODUCTION IN PART OR AS A WHOLE WITHOUT THE WRITTEN PERMISSION OF <INSERT COMPANY NAME HERE> IS PROHIBITED.

		UNLESS OTHERWISE SPECIFIED:		NAME	DATE
		DIMENSIONS ARE IN INCHES	DRAWN		
		TOLERANCES:	CHECKED		
		FRACTIONAL ±	ENG APPR.		
		ANGULAR: MACH ± BEND ±	MFG APPR.		
		TWO PLACE DECIMAL ±	Q.A.		
		THREE PLACE DECIMAL ±	COMMENTS:		
		INTERPRET GEOMETRIC TOLERANCING PER:			
		MATERIAL			
NEXT ASSY	USED ON	FINISH			
APPLICATION		DO NOT SCALE DRAWING			

TITLE:
BOTTOM ASSEMBLY

SIZE	DWG. NO.	REV
A	PVEdwg-4225-0-0	-
SCALE: 1:64	WEIGHT:	SHEET 3 OF 3